

REPORTED SPEECH IN AKOJSE

ROBERT HEDINGER

Summer Institute of Linguistics, Yaoundé, Cameroon

This paper aims to give an explicit characterization of direct and indirect speech by focussing on pronoun reference. By applying the same approach to Akɔjse, a Bantu language of Cameroon, a further category can be established: combined speech, which is a kind of reported speech combining elements of direct and indirect speech. Details of Akɔjse speech sentences discussed include the different forms of the speech introducing particle (reporting particle), the logophoric subject marker and the logophoric reporting particle. It is further shown, that the logophoric elements can be viewed as indicating double anaphora. A note on a possible historical origin for the logophoric forms is included, as well as a note on a simplified re-analysis of Mambila speech types (Perrin 1974).

Le but de cet article est de donner les caractéristiques de citations de style direct et de style indirect en exposant pour chacun le système de référence des pronoms, correspondant. En appliquant les mêmes principes à la langue akɔjse, une langue bantou du Cameroun, une troisième catégorie de style peut être établie: style "combiné", qui présente à la fois des aspects du style direct et du style indirect. Dans l'analyse des discours en akɔjse sont incluses les différentes formes que prend la marque qui introduit la citation, la marque du sujet logophorique et la marque logophorique qui introduit la citation. L'article propose que les éléments logophoriques soient des cas de double anaphora. Une hypothèse sur l'origine historique des éléments logophoriques y est incluse. Enfin, une analyse simplifiée des types de citation du mambila (M. Perrin 1974) est proposée.

0. INTRODUCTION

In this paper¹ the nature of direct and indirect speech, both together referred to here as reported speech, will be examined. Traditional definitions of reported speech will be discussed and shown to be inadequate to account for the complexities found in some Cameroonian languages. It is believed that there are simple, universal characteristics of reported speech which give a systematic account for these various types of reported speech.

After a general discussion attention will be turned to reported speech in Akɔɔse, a Bantu language spoken in Cameroon, looking in turn at the speech sentence, direct, indirect and combined speech, the logophoric subject marker and the logophoric performative marker.

1. THE NATURE OF REPORTED SPEECH

Definitions of direct and indirect speech or discourse probably go back to the Greek grammarians. Whether definitions in current dictionaries have changed much since then is doubtful. So first traditional definitions of reported speech will be examined.

1.1 TRADITIONAL DEFINITIONS OF DIRECT AND INDIRECT SPEECH

Webster's (New World) Dictionary (1976:399) defines a direct quotation as "in the exact words of the speaker". The Concise Oxford Dictionary (1964:345) has the following entry: "direct speech or oration, the words as actually spoken, not modified in reporting." These are possible definitions. But they do not explain why for example 1st, 2nd and 3rd person pronouns are used. The inadequacy, however, really lies with the definition of indirect speech. Webster's Dictionary (1976:716) says the following: "*indirect discourse*: statement of what a person said, without quoting his exact words." In other words, indirect speech is the opposite of direct speech; it simply negates the definition of direct speech. The definition for indirect speech given by the Concise Oxford Dictionary (1964:619) is a slight improvement over Webster's definition: "indirect speech, reported speech, with necessary changes of pronouns, tenses, etc." It rightly says that there are changes of pronouns and tense etc. but it does not say *why* such changes are necessary, nor what controls them. We therefore need to go beyond these definitions in order to give a full account of speech types both for English and languages with more complicated structures.

The Oxford dictionary gives an open-ended list of elements which are changed in indirect speech. Besides pronouns and tenses there are references to time, place, deictics including directional verbs which are changed in indirect speech... In this paper, we will concentrate mainly on the pronoun changes which take place. It is believed that an approach along the same lines will account for the other elements undergoing changes.

1.2 A LINGUISTIC APPROACH TO REPORTED SPEECH

The key to understanding both direct and indirect speech types lies in the fact that all speech has a reference point. This reference point is either the actual speech situation which includes a speaker, an addressee, some thing spoken about, the time of speaking and the

location(s) of speaker and addressee. Or the reference point may be a reported speech situation with its own speaker, addressee etc. Person assignment, references to time and place are oriented towards such a reference point.

Consider example (1) below:

- (1) The taxi driver said to the passenger, "I will take you via the old bridge."

The first clause, containing a speaker, a verb of saying and an addressee, represents a speech situation and will be called reporting clause (RC). The second clause is what the speaker actually said to the addressee, and will be called quotation clause (QC). In the QC there are two pronouns, a first person singular and a second person singular one. Lyons (1968:276) says the following about the category of person: "The category of *person* is clearly definable with reference to the notion of participant-roles: the 'first' person is used by the speaker to refer to himself as subject of discourse; the 'second' person is used to refer to the hearer; and the 'third' person is used to refer to persons or things other than the speaker and hearer." Against this definition it is quite clear that the pronoun I in the QC is coreferential with the speaker in the RC and you in the QC is coreferential with the addressee in the RC. The situation in (1) can be schematized as follows:

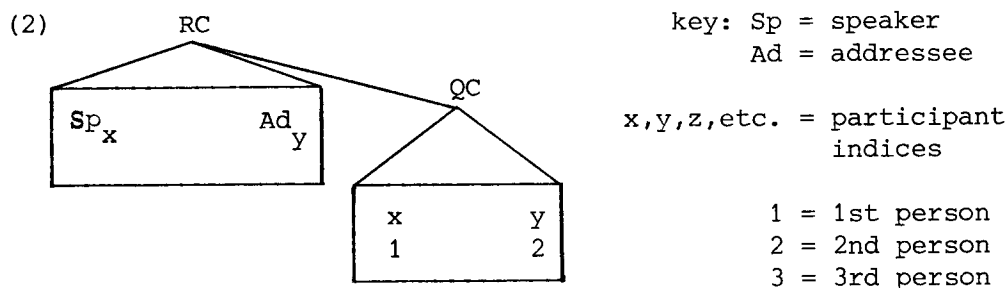

Since x is Sp in the RC it is 1st person in the QC and since y is Ad in the RC, it is 2nd person in the QC.

There are of course sentences like (3) where no RC is present.

- (3) "I will take you via the old bridge."

This utterance is simply a QC identical with the QC in (1), without an accompanying RC. The pronouns I and you cannot refer to a RC but do have an antecedent like pronouns in general have. They refer to a speaker and an addressee; the speaker and addressee of the actual speech situation. To make pronoun reference fully explicit it is necessary to include the speech situation in the analysis, abbreviated

as SS. This somewhat resembles Austin's (1975) "implicit performatives", Sadock's (1969) "hypersentences" or Gregerson's (1979:15) "predicates of mood". A schematic representation of (3) turns out, as expected, to be very similar to the one for (1), cf. (2) and (4).

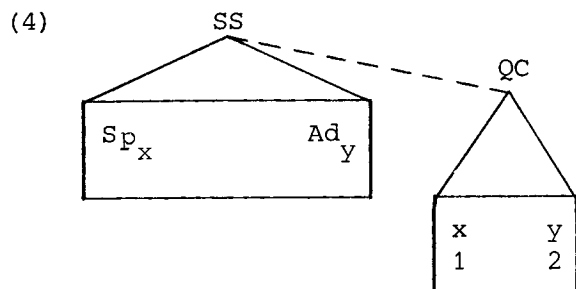

The difference between (2) and (4) are as follows: Instead of a RC there is an SS. In (4) a dotted line connects the SS with the QC to indicate that the SS represents the pragmatic context not manifested as a surface clause. In (2), where the RC is connected to the QC with a solid line, both are present in the sentence (1) as surface clauses.

Example (1) is a report of the speech act in (3). The same speech act may however be reported as in (5).

(5) The taxi driver told the passenger that he would take him via the old bridge.

(5) is again composed of a RC and a QC as in (1). So (5) may be schematized as (6).

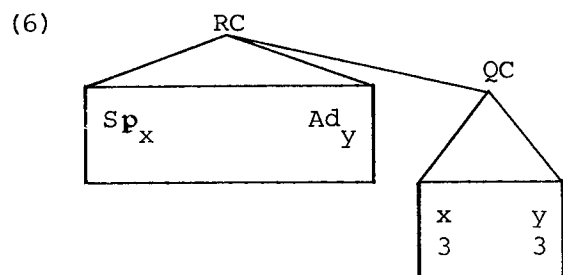

The difference as far as pronouns is concerned lies in the fact that the QC in (5) contains two 3rd person pronouns as opposed to a 1st and a 2nd person pronoun in (1). Cf. (6) with (2). Now in (2) pronoun assignment in the QC is clearly taken from the RC where x is speaker and y is addressee. In (6) on the other hand, since x and y are Sp and Ad in the RC respectively but are referred to by 3rd person pronouns in the QC, pronoun assignment cannot possibly be taken from the RC. This situation forces us to include the SS for (6) where a different speaker reports (5) to a different addressee. Cf. (7) below:

(7)

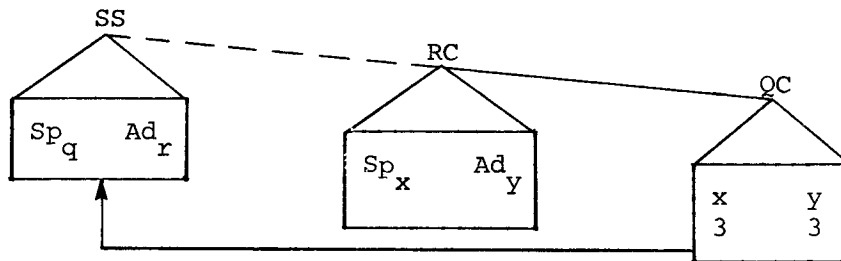

With the SS in (7) pronoun assignment in the QC can be clearly accounted for: x and y are neither speaker nor addressee in the SS therefore they are referred to by 3rd person forms in the QC.

Having had to incorporate the SS in (7) to account for (5) the question naturally has to be asked whether all reporting sentences require the SS to be included in their analysis. Although for a sentence like (1) it does not seem crucial to do so, it seems preferable to represent all reporting sentences consistently by always including the SS.

In keeping with what has just been said (2) needs to be expanded to (8).

(8)

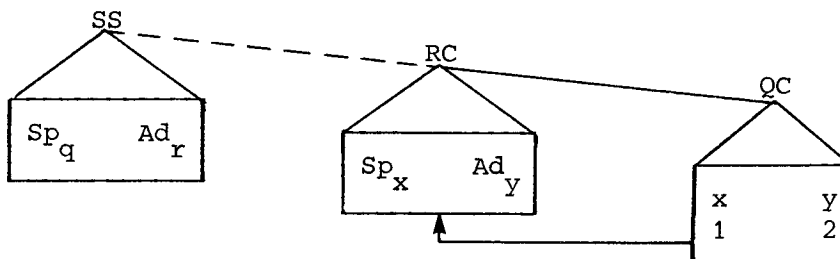

That the RC also takes its orientation from the SS becomes apparent from a sentence such as (9):

(9) The taxi driver said to me, "I will take you via the old bridge".

Example (9) may be represented as (10) below:

(10)

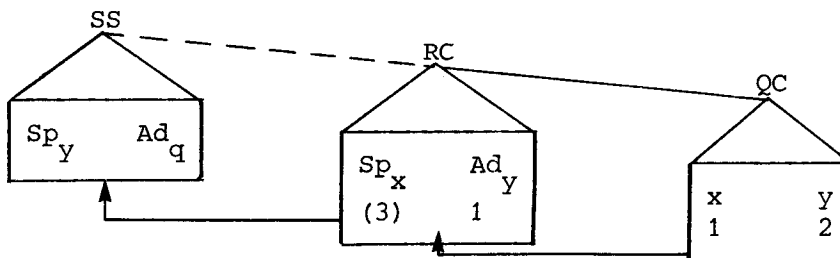

The presence of the 1st person pronoun in the RC finds a natural explanation: y is the speaker in the actual speech situation

(represented by the SS) and therefore refers to himself by a 1st person form in the RC. This RC is therefore clearly oriented towards the SS. The QC in (10) on the other hand is oriented to the RC and takes its pronoun assignment from there, as indicated by the arrows.

In (10) the speaker in the RC is indicated as being referred to by a 3rd person form. The 3 is put in brackets to indicate that there is not a pronoun in (9) but rather a noun phrase (NP). Noun phrases generally are not used by the speaker to refer to himself or the addressee but to what is spoken about. In that sense NP's can be considered as 3rd person forms. An exception to this is vocative phrases which "explicitly identify the addressee" (Gregerson 1979:39) and therefore can be considered as 2nd person forms.

After presenting a general framework for analysing reporting sentences it is now possible to discuss the distinction between direct and indirect speech.

1.2.1 *Direct Speech*

Grimes says (1975:73) that "in direct discourse person assignments are derived...from the immediately dominating verb of saying or thinking". This is one characterization of direct speech. It is narrow in that it focusses only on pronoun assignment. To be able to include other phenomena it could be easily broadened to read as follows: in direct speech, a sentence, paragraph etc, takes its orientation from the immediately dominating reporting clause. This characterization would handle not only pronoun assignment but also references to time, location etc. Seen against this characterization it is clear that the sentences represented by (8) and (10) are in direct speech. In both cases the QC is oriented towards the immediately dominating RC.

The examples so far given were simple in that they contained at the most one RC. There are however speech sentences with two or more RC's, i.e., sentences with multiple embedding. Cf. (11) below taken from Lowe (1969:412):

(11) I said to him, you said to him, you said to me, I saw you.

(11) contains a QC dominated in turn by three RC's. Each layer of embedding is in direct speech and therefore takes its pronoun-assignment from the RC which dominates it immediately. (12) below gives a schematic representation of (11) with the speech situation (SS) made explicit.

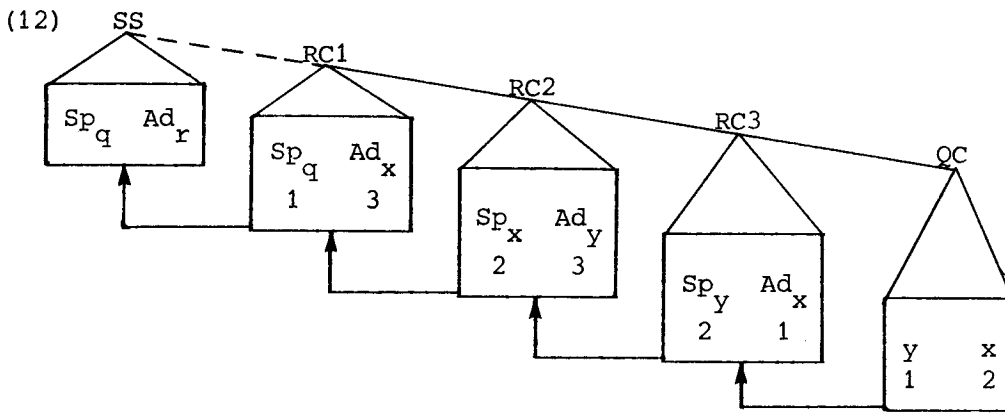

1.2.2 Indirect Speech

Indirect speech differs from direct speech in the following way. Instead of being oriented to the immediately dominating reporting clause, a statement is oriented towards a "performative (here called reporting clause) more remote than the one that dominates the statement immediately" (Grimes 1975:73). It may be oriented to a reporting clause "higher up in the chain of embedding" or to "the implicit performative (our SS) that dominates the whole discourse" (Grimes 1975:321).

Example (5) above, diagrammed as (7) is in indirect speech being oriented to the SS. Example (13) below illustrates indirect speech with a statement (QC) oriented towards RC1 which does not immediately dominate it, cf. with (14).

(13) John said to Peter, "Paul told you that I had gone."

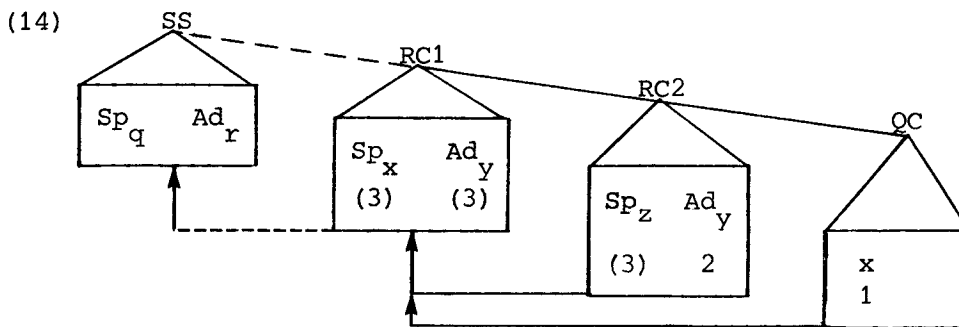

In (14) the QC is in indirect speech, but the RC2 is in direct speech, since both the QC and the RC2 are oriented to the RC1.

Up to now the arrows have been drawn pointing from right to left, expressing visually the relationships of content to the RC or SS. The arrows could equally well be drawn pointing from left to right. In doing so the point of view of the speaker in the SS would be

expressed. Generally speaking in indirect speech the speaker in the SS reports what was said before from *his own* point of view. Cf. (7) redrawn as (15):

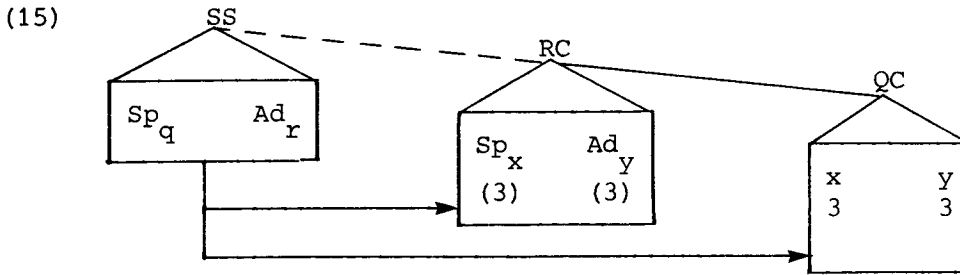

In direct speech, on the other hand, the speaker in SS shifts perspective from his own point of view to that of the speaker(s) of whom he reports speech. By reversing the arrows in (10) this shift of point of view from speaker y to that of speaker x is indicated. Compare (10) with (16) below: (the only difference being the direction of the arrows).

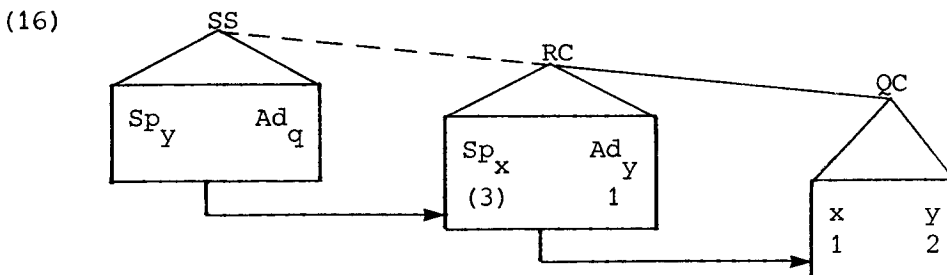

In (11) illustrated by (12), an example of multiple embedding of direct speech, the speaker in SS shifts perspective first from his own point of view to that of the speaker in RC1, then to that of RC2 and finally to that of RC3.

Not always are reporting sentences either all in direct or all in indirect speech. (13) illustrated by (14) above is clearly a case where the speaker in SS neither reports all from his own point of view, nor does he shift to the point of view of each successive speaker in turn. He only shifts perspective once to that of speaker x , so that the RC2 is in direct speech but the QC is in indirect speech. Cf. (17) below:

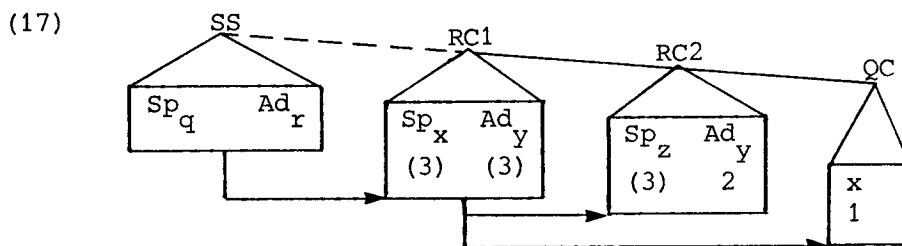

2.3 SUMMARY

It has been shown that at least the choice of pronouns in both direct and indirect speech can be accounted for in a systematic, explicit way. Both direct and indirect speech is oriented to some RC or the SS. In order to handle all cases, it was necessary to include the pragmatic context (SS) which reflects the actual speech situation. Direct speech was shown to take its orientation from the immediately dominating RC, indirect speech from some other, more remote RC or the SS.

3. REPORTING SENTENCES IN AKOJSE

3.1 DESCRIPTION OF THE REPORTING SENTENCE

Reporting sentences typically consist of one or more reporting clause(s) (RC) plus a quotation content (QC). Cf. (18) and (19) below:

RC	QC
(18) bé-lángé b́s ńn bán à-mwé'é ² <i>they-told them this RP voc-friends</i>	bán sê-dèá nyí à-won <i>RP we-like you to-marry</i>
'They said to them, "Friends, we would like to marry you."'	

(18) above has one RC, (19) below contains two RC's, RC1 being of a reduced type.

RC1	RC2	QC
(19) ǎ mè-ńláá wè ńn mǎ wě-bòó <i>RP I-told you this RP you-will-rot,</i>	ǎdì àlúm dé-bòò?é <i>his debt it-will-not-rot</i>	
'He said, "I told you that you would rot but my debt would not rot."'		

In (19) the RC2 together with the QC is of course the quotation content of RC1. This additional detail will not be taken into consideration without losing anything of significance.

3.1.1 The reporting clause

The reporting clause (RC) may be full as in (20) below:

(20) ńjómé'kúb à-làngè mbwé ńn ǎ...
cock he-tells dog this RP...

'The cock told the dog, ...'

containing an optional NP referring to the speaker, a verb of speech, followed optionally by a NP referring to the addressee. With some verbs ńn 'this' may follow. The final element of the RC is what will be called the reporting particle (RP).

When a question is introduced, the question particle kèn occurs after the RP as in example (24) below:

- (24)a. ǎ kèn čě á-bé'lé
 RP Q what he-has-done
 'He asked, "What has he done?"'
- b. wě kèn nzé à-dé wè hén
 RP Q who he-is you here
 'You are asking, "Who is on your place?"'

3.2 DIRECT, INDIRECT AND COMBINED SPEECH

In Akɔɔse, direct and indirect speech as well as a combination of both is found. The distinction between the three types is not overtly marked but they can be distinguished primarily on the basis of pronoun reference. There is no distinction in the PC for all three types. Only the occasional presence of the logophoric prefix points unambiguously to non-direct speech.

3.2.1 Direct speech

Example (25) below is a reporting sentence in direct speech.

- (25) Sp_x Ad_y x1 y2
 Bé-lángé bé nén bán à-mwé'é bán sê-dèé nyí à-wón
 they-told them this RP voc-friends RP we-like you to-marry
 'They said to them, "Friends, we would like to marry you."'

Note the presence of the vocative phrase typical of direct speech.

(25) may be diagrammed as follows:

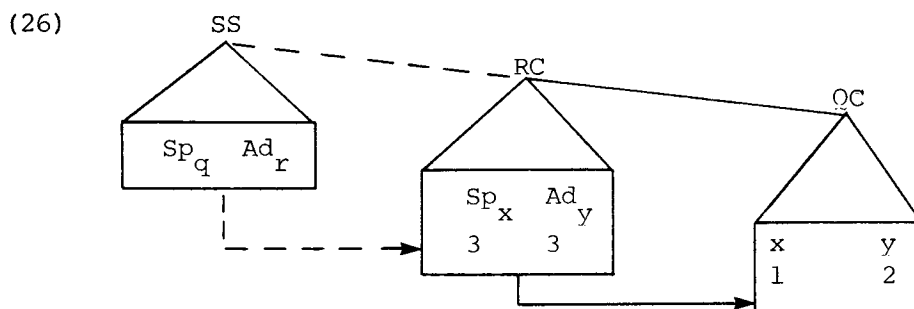

That the QC takes pronoun reference directly from the dominating RC is seen by the fact that *x*, which is speaker in the RC, is referred to by a 1st person form and *y*, which is addressee in the RC, is referred to by 2nd person form.

3.2.2 *Indirect speech*

Indirect speech is illustrated by example (27):

- (27)
- | | | | | | |
|--------------------|--------------------|------------|-----|------------------------|-------------|
| | Sp _x | | x3 | | y3 |
| éčê | ngòndédè | é-kwénténé | bán | bé-'wón | bé |
| <i>those girls</i> | <i>they-agreed</i> | <i>RP</i> | | <i>they-will-marry</i> | <i>them</i> |
| | (cl 10) | | | | |
- 'Those girls agreed to marry them.'

This may be represented as (28):

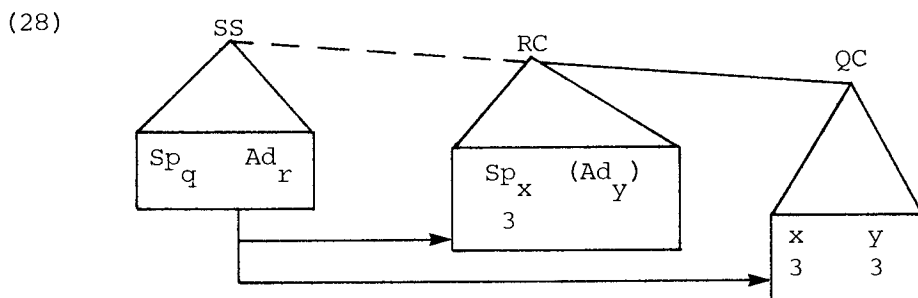

In the RC the addressee is not expressed overtly and is therefore put in brackets in (28). The QC is clearly reported from the point of view of the speaker *q* in the SS. Therefore *x* and *y*, neither speaker nor addressee in the SS, are referred to by 3rd person forms in the QC.

Perhaps the verb *kwéntén* 'to agree' never dominates direct speech. The classification of the reporting verbs as to whether they may or may not be followed by direct speech awaits further study.

3.2.3 *Combined speech*

Combined speech may be characterized as follows: In the same QC the speaker is referred to indirectly, i.e., by 3rd person forms. The addressee on the other hand is referred to directly, i.e., by 2nd person forms. Cf. (29):

- (29)
- | | | | | | | | |
|-------------|--------------------|-------------|-------------------|------------|-------------|--|----|
| | Sp _x 3 | | y2 | | x3 | | y2 |
| ǎ kèn | nzé è-kàlé | mètóm, | mé-'bél | wè | čán | | |
| <i>RP Q</i> | <i>if you-told</i> | <i>lies</i> | <i>he-will-do</i> | <i>you</i> | <i>want</i> | | |
- 'He asked, "If you told lies, what should I do with you?"'

In (29) the RC consists of only the RP plus question particle *kèn*.

The QC consists of a sentence with two clauses. (29) may be represented as follows:

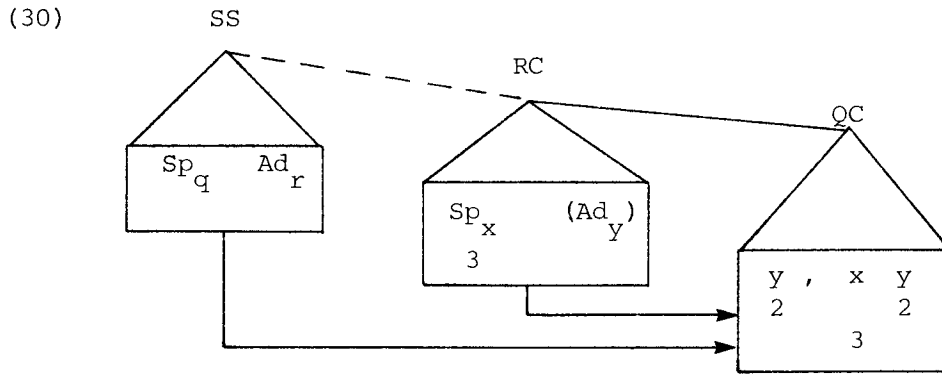

As is clearly seen in (30) *y*, the implied addressee in the RC, is referred to by 2nd person forms in both clauses in the QC. *x*, on the other hand, is speaker in the RC, but is referred to by a 3rd person form in the QC. So the QC has a combination of direct and indirect pronoun reference.

It is significant to note that in combined speech vocative phrase occur which, as was said, is typical for direct speech. This is not surprising since the addressee, to which vocative phrases refer, is referred to directly. Cf. (31):

(31)

Sp_x	Sp_3	(Ad_y)		$y2x3$
mwàád	à-làngè	hjom	ǎ à-hjom,	ngánè nyú'mé nyí-dyě
<i>wife</i>	<i>she-tells</i>	<i>husband</i>	<i>RP voc-husband,</i>	<i>as you-she 2pl-have</i>
				<i>stayed</i>

'The wife said to her husband, "Husband, since we have stayed

	$x3$		$y2$	$y2$	$x3$
nén ...	ǎ mbwé'é	mé-'wéé	ǎ é-kè	è-légéd	mé
<i>"like this"</i>	<i>RP day-when</i>	<i>she'll-die</i>	<i>RP you-go</i>	<i>you-leave</i>	<i>her</i>

like this... the day when I die, go and put me

á son tē
loc. grave in

in a grave."

One interesting fact of combined speech involves what we called complex pronouns (Hedinger 1981). In example (31), diagrammed in (3) two participants are referred to by one pronoun *nyú'mé* 'you and he. However, one participant *y* is referred to directly and the other participant indirectly by the same pronoun.

(32)

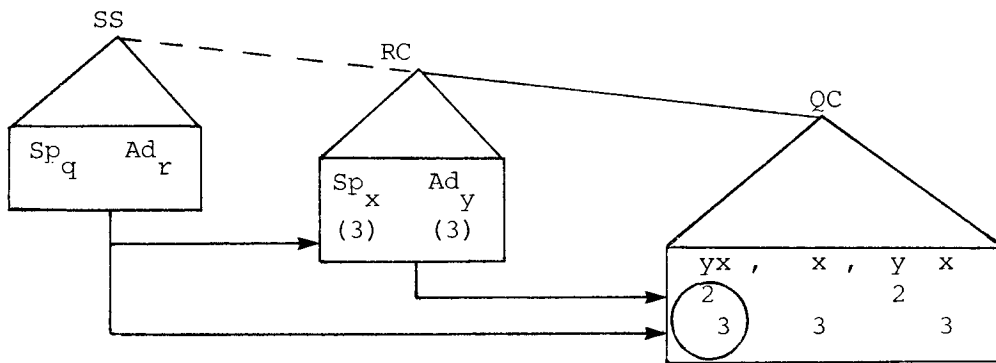

Note that *y*, the addressee in the RC is 2nd person in the QC. *X*, the speaker in the RC, on the other hand is 3rd person in the QC. Numbers 2 and 3 are circled to show that they are together expressed by the same pronoun. Combined speech is not unique to Akɔɔse. This is clear from Perrin (1974), Thomas (1978), and Hyman (1979), who report similar phenomena for languages in Nigeria and Cameroon. Grimes (1975:321) includes the following personal communication from Donald Webster about Abidji of the Ivory Coast: "Any reference to the speaker of a quotation inside the quotation is made by indirect reference, and any reference to the person spoken to is made by direct reference."

The existence of combined speech, which is established on the basis of pronoun reference, raises the question whether other parts of the QC, i.e., deictics, temporal and locational references, etc., are controlled according to the direct or the indirect principle in combined speech. Since we don't have enough material to answer that question, and also it lies outside of the scope of this article, it will not be addressed here.

3.3 THE LOGOPHORIC FORMS

3.3.1 *The logophoric subject marker*

In example (29), what was indicated as a 3rd person prefix is in fact the logophoric subject marker (LSM) rather than the ordinary 3rd person singular subject marker (SM) à-. The LSM is always used in indirect and combined speech where in direct speech a 1st person singular SM is used. In example (33) the reporting sentence from (29), having been transformed into direct speech, is given.

(33) Sp_x³ y₂ x₁ y₂
 ǎ kèn nzé è-kàlé mètóm, mǎ-'bél wè čán
 RP Q if you-told lies I'll-do you what

'He said, "If you told lies, what shall I do with you?"

Note that the only difference between (29) and (33) is the má- 'LSM' vs. mǎ- '1st person singular SM'. Cf. (34) with (30).

(34)

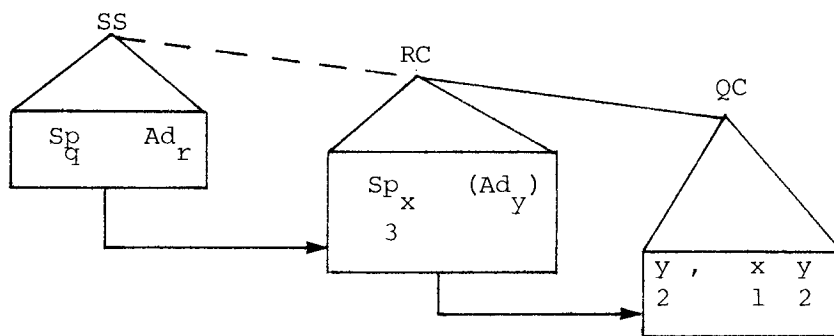

The function of the LSM is to distinguish the speaker of the reported utterance from any other 3rd person. Compare the following examples:

(36) Sp_x 3 z3
 à-hóbé ǎ á-kàg
he-said RP he-should-go

'He said that he (someone else) should go.'

(37) Sp_x 3 xLOG
 à-hóbé ǎ mé-kàg
he-said RP he-should-go

'He said that he (himself) should go.'

Both (36) and (37) are indirect speech. In (36) the speaker of the RC is not coreferential with the subject of the QC. In (37), on the other hand, the speaker of the RC is also subject of the QC. Therefore the LSM has to be used in the QC. (36) and (37) may be represented as (38) and (39) respectively.

(38)

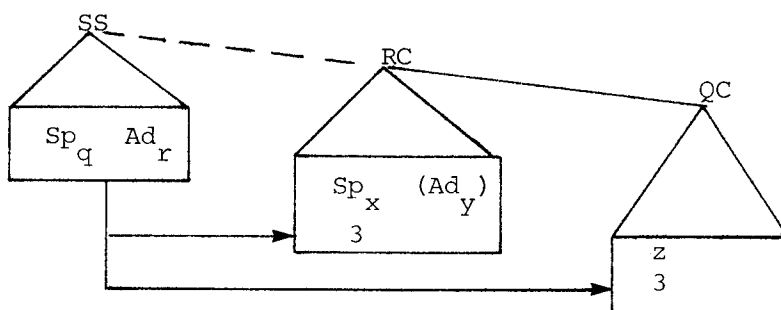

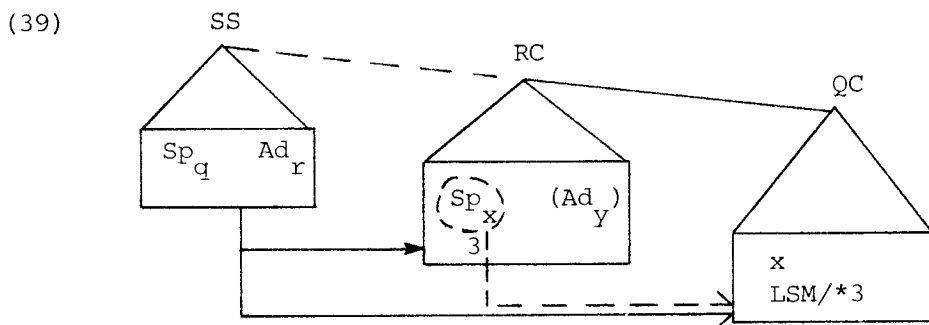

(It was stated above that (36) is indirect speech. It could, of course, also be considered as direct speech since there is nothing in this example to distinguish them.)

3.3.2 *The logophoric as double anaphora*

In (39) the LSM is indicated as having double anaphora. First of all, the LSM takes indirect reference from the SS. That this is the case is clear from the following facts: when all persons are changed to plural forms, then the ordinary 3rd person plural SM is used, whereas in the singular the LSM occurs (there is no plural LSM). Cf. (40):

(40) Sp_x^3 x^3
 bé-hóbé bán bé-kàg
 they-said RP they-should-go

'They said that they (themselves or some other people) should go.'

As indicated in the gloss, the distinction between speaker vs. non-speaker in (36) and (37) is neutralized in (40). Secondly, the LSM refers to the speaker in the RC which dominates it immediately; in other words, it is only present when the subject referred to is coreferential with the speaker in the RC.

The proposal made here is that the logophoric can be characterized as being a case of double anaphora.

3.3.3 *The LSM as a second person reference*

In 3.3.1 the LSM was shown to be in one sense a 3rd person anaphoric. This was seen when compared with the plural counterpart to the same sentence (37) and (40). This, however, is not the only use. Cf. example (41) below where the LSM refers back to a 2nd person speaker.

(41) Sp_r^2 rLOG/*2
 è-hóbé wě mé-kàg
 *é-
 you-said RP you-have-to-go

This may be represented as (42):

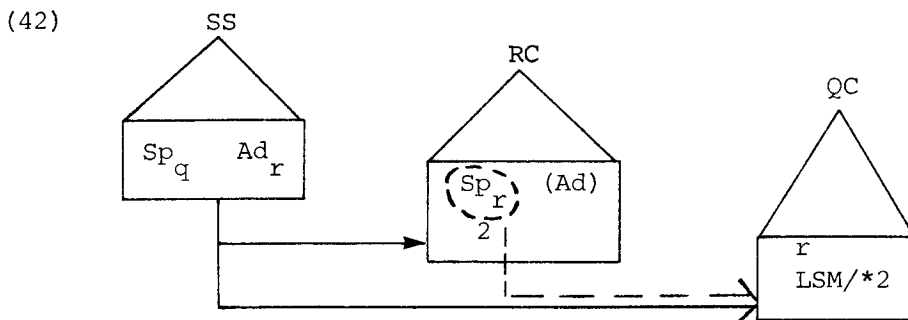

The speaker r in the RC is referred to by a 2nd person SM, because he is the addressee in the SS. In the QC r is not referred to by a 1st person SM. If it were, it would be direct speech. Nor is it referred to by a 2nd person form, which would be inappropriate under the given referential indices. Rather the LSM is being used taking indirect reference from the SS (cf. the solid line) as well as referring to the speaker in the RC (cf. the dotted line). That here the LSM can be considered a 2nd person is suggested by the following reasons:

Firstly, the r refers back to the SS where r is addressee, which is always 2nd person.

Secondly, when transformed to the plural a second person plural SM appears in the QC. See (43):

- (43) $Sp_r 2$ $r 2$
 nyí-hóbé bán nyí-kàg
 you(pl)-said RP you(pl)-have-to-go
 'You said that you have to go.'

Thirdly, the gloss in (41) suggests a 2nd person. The question arises whether the LSM is also used when a 1st person speaker is coreferential with the subject in the QC. This is not the case. Cf. (44), which is indirect speech, and (45), which is direct speech.

- (44) $Sp_q 1$ $q 1$ $x 2$
 ñ-lángé mǎ mǎ-bě wě mǎné
 I-said RP I'll-give you money
 'I said, "I'll give you the money."'

- (45) $Sp_q 1$ $q 1/*LOG$ $x 3$
 ñ-lángé mǎ mǎ-bě mé mǎné
 I-said RP I-will-give him money
 'I said that I would give him the money.'

In both direct and indirect speech 1st person SM's are used. As indicated in (45) the presence of the LSM is inappropriate. (46) and (47) below represent (44) and (45) respectively.

(46)

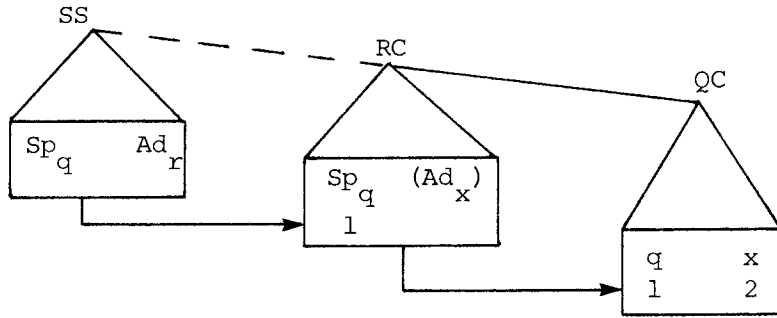

(47)

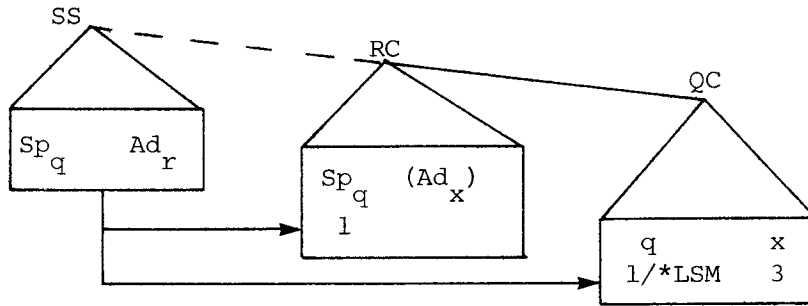

It should be pointed out that there is no LSM for the plural. Nor is there any logophoric subject or object pronoun or possessive pronoun as found in some languages like Tikar (Stanley 1982) and other African languages (Hagège 1974). The grammatical person of pronouns and possessives in reported speech is assigned according to the rules elaborated in 2.2. Just one example will be given here:

(48) Sp_x³ Sp_y² z₃ y₂ yLOG
 ǎ è-hóbè wě bé-hìlìnàad wè páá wě mǎ-sêl
 RP you-say RP they-should-give you cutlass RP you-should-cut

'He said, "You said that they should give you a cutlass so

mòd òlò
 person head

that you can cut someone's head off.'"

(49)

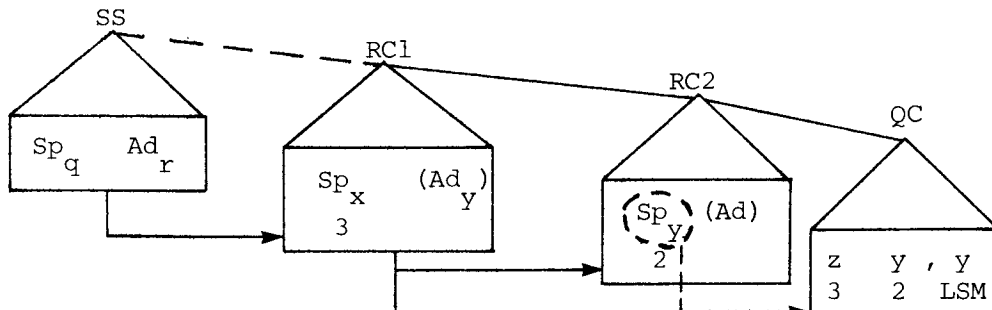

pronoun before the prefix. The same surface form results in rapid speech. It would appear to be a plausible explanation that the LSM is derived from an emphatic subject form since similar strategies are found in other languages to distinguish speaker from nonspeaker. In English, for example, an emphatic structure may be used to identify the subject as being the same as the speaker. Cf. (52)b. In (52)a, however, the second he is ambiguous whether it refers to the speaker or someone else.

(52) a. He said that he would do it.

b. He said that he himself would do it.

Support for this LSM being grammaticalized in Akoose comes from the following fact. The LSM may itself be preceded by the pronoun mé to emphasize it:

(53) \check{a} m \hat{e} m \acute{e} -kìí
RP he he-has-gone

'He said, "I have gone" or "I am going now."'

Furthermore, speakers of the language react against separating the LSM m \hat{e} - into m \acute{e} / plus \check{a} -.

The LRP m \acute{e} ' \acute{e} could have a similar diachronic derivation: m \acute{e} + \check{a} > m \acute{e} ' \acute{e} . The tone rule HLH > H'H is frequently observed in synchronic contexts in the language.

4. REPORTED SPEECH IN MAMBILA

In Perrin (1974) Mambila was analyzed as consisting of five distinct types of speech based on pronoun reference. We think that a reanalysis in our framework is possible, thus considerably simplifying the analysis. In the following table Perrin's categories are related to our reanalysis.

<u>Perrin (1974)</u>		<u>reanalyzed</u>
Full direct	→	Direct
Mixed direct	→	} Indirect
Reduced direct	→	
Indirect	→	
Combined	→	Combined

The key to this reanalysis is the fact that we consider the logophoric pronoun (in Mambila neh, Perrin 1974:29) as a case of double anaphora having both direct and indirect reference. Perrin chose to focus exclusively on the direct reference thus leading her to a multiplication of speech types. By considering the logophoric pronoun to be primarily (but not exclusively) an indirect reference form a simpler analysis is possible.

FOOTNOTES

¹Work on this paper was started during a workshop held in Yaoundé under the auspices of the Société Internationale de Linguistique in 1980. I would like to express my appreciation to the General Delegation for Scientific and Technical Research of the United Republic of Cameroon for giving authorization to work on this language. I am indebted to Prof. Ursula Wiesemann for stimulating discussions, to Stephen C. Anderson for commenting on an earlier draft of this article and to those speakers of the language, especially Mr. G. E. R. Metuge, without whose help this work would have been impossible.

²The apostrophe occurring between two high tones indicates that the second high tone is downstepped relative to the preceding high tone.

REFERENCES

- Austin, J.L. 1975. *How to Do Things with Words*. Oxford, Clarendon Press.
- Dorsch, Heinrich. 1910/11. 'Grammatik der Nkosi-Sprache' in *Zeitschrift für Kolonialsprachen*, Jahrgang 1:241-83.
- Gregerson, Kenneth. 1979. *Predicate and Argument in Rengao Grammar*. Dallas, SIL/UTA.
- Grimes, Joseph E. 1975. *The Thread of Discourse*. The Hague: Mouton.
- Hagège, Claude. 1974. 'Les pronoms logophoriques' in *Bull. Soc. Ling.* 69:287-310. Paris.
- Hedinger, Robert. 1921. 'The pronouns of Akoose' in *Studies in African Linguistics* 12:277-90.
- Hyman, Larry M. 1978. 'The Phonology and Noun Structure' in *Aghem Grammatical Structure*, ed. by Larry M. Hyman. Southern California Occasional Papers in Linguistics, no. 7. Los Angeles: University of Southern California. Pp. 1-72.
- Leech, Geoffrey N. 1980. *Explorations in Semantics and Pragmatics*. Amsterdam: John Benjamins, B.V.
- Lowe, Ivan. 1969. 'An algebraic theory of English pronominal reference' in *Semiotica* 1:397-421.
- Lyons, John. 1968. *Introduction to Theoretical Linguistics*. Cambridge: University Press.
- Perrin, Mona. 1974. 'Direct and indirect speech in Mambila' in *Journal of Linguistics* 10:27-37.
- Sadock, Jarrold. 1969. 'Hypersentences' in *Papers in Linguistics* 1:2:283-370.
- Stanley, Carol. 1982. 'Direct and Reported Speech in Tikar Narrative Texts' in *Studies in African Linguistics* 13:31-52.
- Thomas, Elaine. 1978. *A Grammatical Description of the Engenni Language*. SIL Publications in Linguistics 60. Arlington: University of Texas.