

# TOWARDS A GRAMMAR OF THE IVIE FOLKTALE: OYAKHIRE

R.A.Masagbor  
University of Benin, Nigeria

The Ivie folktale lends itself to some of the classic models of basic analysis as that of the Russian writer of *The Morphology of the Folktale*, Vladimir Propp, who divides the tale into the story and the discourse. Thus it has both integrational and distributional components that ensure the concatenations as well as the transformations in the tale.

In our analysis of the folktale, Oyakhire, we show the kernel or minimal story, then an inventory of other elements that placed on a cause-effect axis/sequence help to establish a combination that generates this story. This ensures a creativeness as well as similarity of folkloric details in the various reproductions of the tale irrespective of narrator, time and place.

La tradition populaire Ivie se prête à quelques models d'analyse classique de base comme celle de l'écrivain russe, Vladimir Propp, auteur de *La morphologie de la tradition populaire*, qui divise le folklore en conte et discours. Il a donc aussi bien les composants intégrationnel et distributionnel qui assurent les concaténation ainsi que les transformations dans le folklore.

Dans notre analyse du folklore, Oyakhire, nous démontrons le conte noyau, puis un inventaire d'autres éléments qui établissant une séquence de cause-effet, aident à établir une combinaison qui engendre ce conte. Cela assure de la créativité ainsi qu'une similarité de détails folkloriques dans les reproductions diverses du folklore indépendamment du narrateur, du temps et du lieu.

## 1. BACKGROUND

The typical Ivie folktale belongs to the narrative genre handed down from generation to generation and therefore of an origin that seems lost in the unknown past. Gerald Prince points out that everybody distinguishes stories from non-stories. Everybody has certain intuitions or has internalised certain rules about what constitutes a story and what does not. This is perhaps why, in retelling a folktale over the years, there is a recognisable sameness about it no matter the changes of narrator, or time and place of narration.

The Russian formalists (particularly Vladimir Propp) divide the form of the tale into the story (consisting of the logic of action and the syntax of characters) and discourse (comprising the aspects and modes of the narrative). Barthes (1977:86) clarified the relationship by citing Emile Benveniste's theory of two types of relationships in language - distributional and integrational - responsible for the concatenation of events in, as well as transformations of, the tale. In the light of these elucidations, we feel that there is an underlying system or grammar in the tale that makes it possible, once internalised by the narrator, and within the closed contential units of the tale, to generate each time a tale of sameness or similarity as told by some other man now or some time past or even some time to come.

## 2. PURPOSE

In this paper, we intend to borrow a leaf from transformational generative grammar in seeing how certain transformations are generated, while keeping our main thrust structural, since we shall be reducing the sequences of the tale into their constituents. By so doing we hope to produce an inventory of elements which help to establish a calculus of available combinations. While we consider the deeper thematic structure and meaning of the tale, our main analysis is based on Gerald Prince's 'A Grammar of Story' (1973). He establishes the notion of the minimal story consisting of events conjoined in such a way that the first precedes the second, and the second precedes the third causatively. Brémond (Barthes, 1966:60) refers to this as 'séquence élémentaire' made up of initial

event, 'conduite' or channel of realisation and the resultant action. A series of minimal stories through different types of transformations such as embedding, alternation or linking up could become a complex tale.

### 3. THE OYAKHIRE STORY

Our first approach is to establish the type of story Oyakhire is - minimal, kernel or complex. Structurally the story contains the following macro structural events. The first is the Oba-pregnant woman encounter, the ensuing rapport and eventual marriage of the Oba and the woman's daughter. The second macro structure is Urhonyavhegbe's vicariously induced infidelity. The third macro structure is the events of the naming ceremony giving rise to Oyakhire/Oba animosity and the many episodes of tasks and counter moves aimed at eliminating Oyakhire.

It is clear that we have more than a minimal story here. Let us take the very first move of the tale - Oba goes for a walk and encounters a pregnant woman whom he helps - one event. The second event is that the woman gives birth and Oba sends a gift. The third event is the marriage of Oba and Urhonyavhegbe (daughter of erstwhile pregnant lady). Following Gerald Prince's postulations on the minimal story, it seems this requirement is met. This agrees with Claude Bremond's elementary sequences of the story: 'initial event, schema of realisation and resultant action' (Barthes, 1966:60). In the second event of this first move/episode, the Oba, in helping the woman, had promised to marry the child born of the pregnancy if she turned out to be a girl. Thus we see that event number two leads causatively to the third.

Within the Urhonyavhegbe-orphan-Egyi/Oba episodes, one also finds a cluster of elementary sequences. Urhonyavhegbe has affairs with the orphan, Egyi discovers, tells the Oba, comes back to plant cuffs on the unfaithful wife and her lover. The lady's mother/father come respectively to diffuse the tension by acting as extricators. The Oba compensates the parents-in-law for the embarrassment. The analyst observes that there is more than a Kernel story here - there is, for example, embedding of the episode of the extricating parents.

In the Oyakhire-Oba axis, there is a concatenation of episodes in the form of tests/tasks and resolutions. With these ramifications, it is valid to say the story is complex.

### 4. GRAMMAR OF THE FOLKTALE

We are now left with working out the grammar of this particular folklore. Here we must take into account the narrative syntax, the narrative lexicon and the narrative semantics. The narrative syntax, referred to as motif (Vasilevski in Todorov, 1981:48) or function (Vladimir Propp), could be glossed for our purpose as per Todorov's definition (1981:48) of narrative proposition, and is constituted by agents and predicates comprising dynamic or static motifs. Bremond (Todorov, 1981:48) further clarifies agent as subject or object i.e. agent and patient respectively. The narrative lexicon is very much related to the syntax in that it presents the analyst with the content elements of the story. The narrative semantics dovetails into the syntax in presenting the reader /analysts with the meaning/message component. At the level of the word, this has to do with the signification, while taken at the macro-structural level it is the symbolic message that is portrayed.

In presenting our rules for the grammar of the folktale from the generative transformational perspective, the following symbols will be used.

- |        |   |        |   |
|--------|---|--------|---|
| S.A.   | = Structural analysis                     | N.Act. | = Narrative Active event                              |
| S.C.   | = Structural change                       | N.St.  | = Narrative Stative event                             |
| C.Cl   | = Cluster of conjunctive features         | C.F.   | = Conjunctive feature                                 |
| N.Sec. | = Narrative Sequence                      | C.Ft   | = Conjunctive feature indicating two conjoined events |
| N.Ep.  | = Narrative Episode                       |        |   |
| C.T.   | = Conjunctive event indicating chronology |        |   |

The following are the derivational rules for the Oyahire folktale:

1. S.T.            —> N.Sec(1) + C.Cl. + N.Sec(2) + C.Cl. + N.Sec(3)
2. N.Sec         —> (N.Ep (C.Cl + Ep/----)  
                      ((Ep + C.Cl) N.Ep )
3. N.Ep         —> ep (C.Cl + Ep)
4. C.Cl         —> (C.Ft + Sub C.Cl/---- + N.Ep + ---- + N.Ep + ---)  
                      (C.Ft (Sub C.Cl)
5. ep           —> (E.Stat)  
                      (E.Act)
6. C.F         —> (C.Ft/---- + ---- + In E.Stat -)  
                      (C.Ft

Put in the form of a tree diagram we have the following structure.

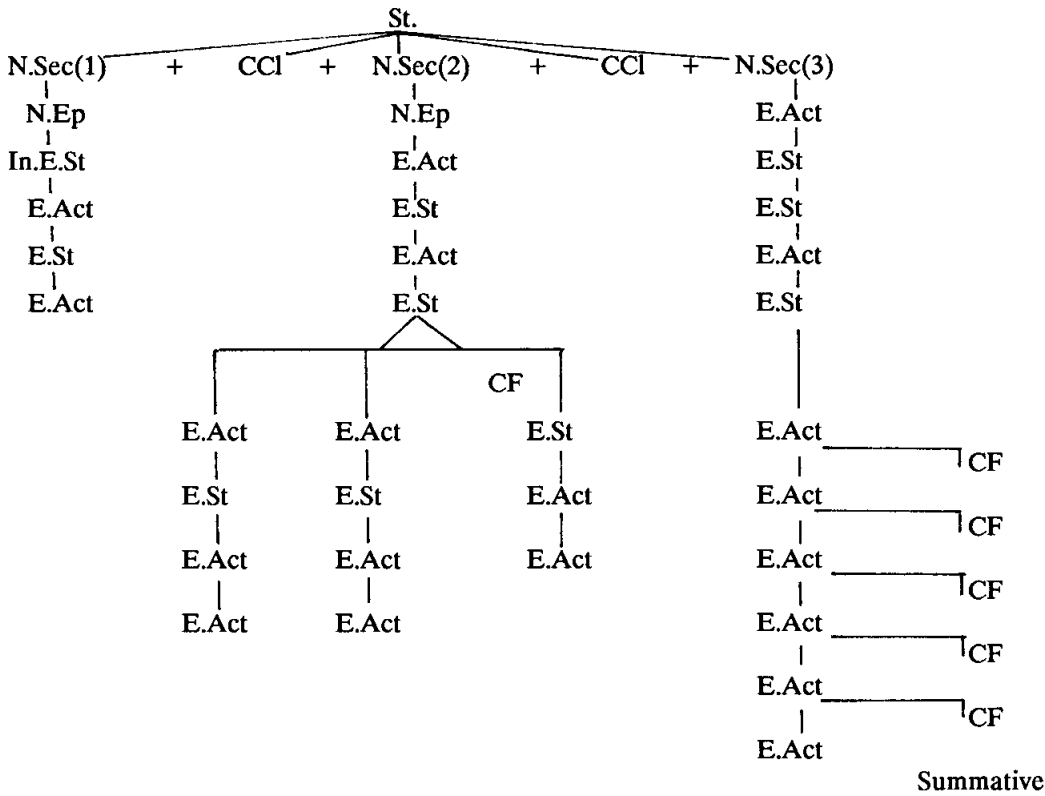

## 5. APPLICATION OF THE RULES TO THE STORY

A breakdown of the above rules would give us the following expressions:

Rule I: 1 to 4

**Ereghẹ oghwo o laa, Oba o bhe a laa...**  
Once upon a time, there lived an Oba...

**O bhe akhi ududumhi okpotso.**  
She grew to become a mature lady.

The intervening conjunction feature is:

**Ele ne ke lele ro bhe, eleyo l'ọ ghwo lo m'Oba elue.**  
The day that she was brought, that day alone did she see the Oba.

## Node 2:5-21:

**Nene r'elue khuo e tie khi we w'evha lamaa.**  
While waiting on her they say they won't allow (her going to fetch firewood).

**Urhonyavegbe o khi le a l'ogw'ore...**  
Urhonyavegbe decided she was going a firewood fetching...

**Rari khi li zughu, ogbo o vha pfa shi o vh'eke**  
Because they were shabby nobody paid attention to him

**no ti o lina khi nen'a khu o vu.**  
no matter what they did before they drove him away.

The intervening cluster of conjunctive features start:

**Abi Urhonyavegbe o ke ro ramhi apfe oni eli ogota oyo, o vi'omomose.**  
When Urhonyavegbe got home that afternoon she gave birth to a baby boy.

The third node of events 22-74 begins with:

**Ogbelẹ ozi ishila, a ghie a lu Oba kọ r'eva ni on'omọ...**  
On the seventh day, the Oba was sent for to give the child a name...

and ends:

**ene nyame Oyakhire wewe kh'ene ki 'ogbo ne ze ki eboh amo ena.**  
Those who saw Oyakhire, they were those who are great native doctors today.

Rule II: N.Sec ---> (N.Ep(C.Cl + ep/————))  
((ep + C.Cl) N.Ep ) gives us the concatenated series of episodes in three phases cited in Rule I above i.e. 1-4, 5-21 and 22-74.

Rule III: N.Ep ---> ep (C.Cl + ep): by applying this rule alternatively the tale progresses. The following are excerpts from these concatenated episodes.

2 **Ogbelẹ oghwo o ko gwe liyo lase, o mē ọkpotso n'ọ mē.**  
One day he came out again he saw a pregnant woman.

**Ele na ke lele bhe, eleyo l'oghwo l'ọ Oba elue.**  
The day they arrived, that day alone did she cast her eyes on Oba.

- 41 **Or'otuemhi n'ọ li ọ kọ, Ogbha, o via o gwe ọli amoamoamo**  
He gave him tuba of yam, asked him to plant it, so that it sprouts, matures and he harvests it the same day.

**O gbigbi ọ ghile...**  
let it produce seedlings for him...

- 42 **Ọ li, 'taa nyanya ru'ose ali emi khu chile vh'alo a.'**  
He said, 'Quickly take the crab and the yam and get out of my sight.'

**Oyakhire ọ vo ọ gwe je.**  
Oyakhire left and went home.

**Rule IV:** Application of this rule supplies us various conjunctive features. C.Ft indicating conjoining of two events as in events 19 and 20 conjoined by

**Eleyo o ke ramhi, e romhi**  
When it got to the appointed day, they swore.

also 22-23:

**abhi Urhonyavegbe ọ ke ọ ramhi apfe oni el'ogoto yọ, Ovi'om'omose.**  
When Urhonyavegbe got home that afternoon she gave birth to a baby boy.

also 40-41:

**O ke gwe li kekeke, Oba ọ gwe gie a luọ.**  
A little while later, Oba sent for him again.

Others of this type include 47-48.

The second type of conjunctive feature C.Ft marks chronology:

13-14 is linked by **Ugbel ioze'se** (on the third day)...;

19-20 **Eleyo o ke ramhi** (on the appointed day)...;

40-41 **Ogbo lefe gbe** (in the early hours of dawn);

40-41 **O ke gwe li kekeke** (yet a little later);

45-46 **On'ogbele no lefe rokhasẹ o ke ramhi** (when the day he was going to show came)...;

47-48 **O ke gwe tese** (some time later)...

**Rule V:** ep ---> (E.Stat)  
(E.Act)

generates the 73 events alternating unequally in stative and active events -

E.Stat<sub>1</sub> + E.Stat<sub>2</sub> + E.Act<sub>3</sub> + E.Stat<sub>4</sub> + CCl + E.Stat<sub>5</sub> + E.Act<sub>6</sub> + E.Stat<sub>7</sub> + E.Stat<sub>8</sub>  
+ E.Stat<sub>9</sub> + E.Act<sub>10</sub> + E.Act<sub>11</sub> + E.Stat<sub>12</sub> + E.Stat<sub>13</sub> + CFt + E.Stat<sub>14</sub> + E.Act<sub>15</sub> +  
E.Stat<sub>16</sub> + E.Stat<sub>17</sub> + E.Stat<sub>18</sub> + E.Act<sub>19</sub> + CT + E.Stat<sub>20</sub> etc.

**Rule VI:** specifies the elements treated in Rule IV.

Rule VII: generates all stative sentences such as:

**Eṛeḡhe ogwo o laa, Oba o bhe a laa.**  
Once upon a time, there was an Oba.

**Oḡpotso o kha vi'omomose o zo vh'ukpokya.**  
When a woman gives birth to a male child he chooses him as his friend.

**O kha ke ki om'kpotso, oror mhue no ke fu.**  
If, however it is a girl, he marries her when she's grown up.

In the tale there are about 47 such stative statements.

Rule VIII: generates active events such as:

**O bhe a kyese itsua gyi'nyio abh'o ke ro suo.**  
He sent gifts to her later on hearing of her safe delivery.

About 26 such active events are in alternating transformation with stative.

## 6. CONCLUSION

Gerald Prince models his analysis on European languages where verbal category is clearly defined as dynamic or stative - the dynamic having the capacity of taking the progressive. For our analysis we have used a cluster of sentences and their content meanings. An optional aspect that has not been taken into account is the musical intermission. This could be an instance of a disjunctive feature embedded with no particular thematic contribution to the tale but meant to raise the flagging interest.

We have established that the folktale, a linguistic artifice of our culture, can be generative within close content boundaries. This can be described through a structural analysis - the type that has been done.

The analysis done so far shows the concatenation of events in the tale from the initial events (stative/non-stative) to the concluding or summative events. An interpretative semantic schema helps to elucidate our analysis i.e. at the deeper level the logic of action shows the motivation of the moves in the story. It helps, too, to show the blend of the surface structure with the deeper structure. Thus, following Greimas's (1984:xxxii ff) semiotic quadrangle we have the following schema:

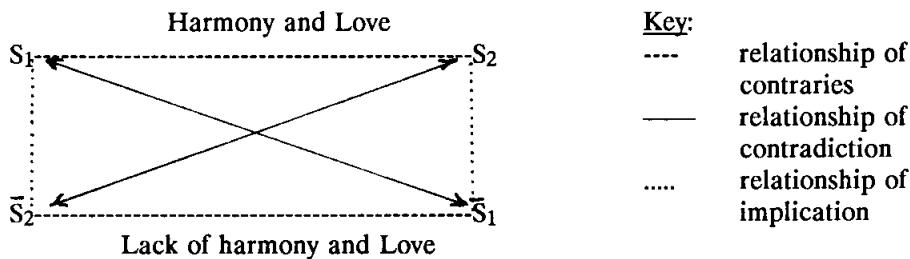

The above diagram shows the deeper level of the message of the tale covered from the interpretative semantic aspect. The second diagram below shows the sequential transformation of events to realise the message of the tale:

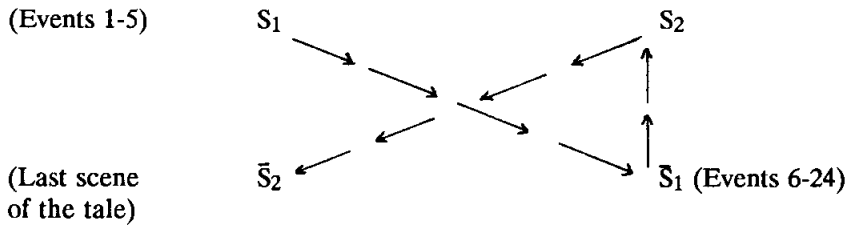

The above diagram suggests that between  $S_1$  and  $\bar{S}_1$  events 1-5 run their course, but the main thrust of the tale 6-24 and 24-73 occur schematically from  $\bar{S}_1$  to  $S_2$ , and  $S_2$  to  $\bar{S}_2$  respectively. Part of the complexity of the tale, however, is that the first macro-structure i.e. Oba-woman encounter, birth and marriage of Urhonyavhegbe and the subsequent unfaithfulness can as well be plotted on our quadrangle just as the story centred on Oyakhire can.

#### APPENDIX -- OYAKHIRE (partial display)

- 1  
E.St. **Ereghẹ oghwo o laa, Oba ọ bhe a laa. Ọkpotoso ọ kha vi'omose, ọ zọ**  
Once upon a time, there lived an Oba. When a woman begets a male child  
he chooses him  
**vh'ukpokya. Ọ kha ke ki om'okpotso, ọ rọ mhue nọ ke fuu. Ogbẹlẹ ghwo**  
for a friend. If it is a female child, he marries her when she grows up. One day
- 2  
E.St. **ọ ke gwe liyọ lase. ọ mẹ ọkpotoso nọọ nẹẹ. Oba ọ li kha via**  
she went for a walk, and saw a pregnant woman. The Oba said when you give  
birth  
**khọ ki om'okpotso, mhemh 'ia mholọr. Ọ bhe a kyese itsua gy'inyọ ọ abh'ọ**  
and it's a girl I shall marry her. He sent gifts to her later on hearing of her  
safe
- 3  
E.Act. **ke rọ suọ. Ọ ke tẹse ọn'omọ ọ bhẹ a fuu, ọ tẹ n rẹ l'oghw ue.**  
delivery. After a long time she became a mature lady.  
**Ọba ọ ghe a nyalu igyiẹde, ọ wẹ gb'elami gyi lẹ. A bhẹ a ny'emenale**  
Oba sent to hunters to go into the forest and get him game. Food was  
prepared for sumptuous  
**ẹ le el'igbe al'esẹ gbadaa. Ogbẹlẹ n'okp'eshimi o bhẹ a kemhi ẹtsekẹ ni**  
en'iqgbọ kuu.  
feeding for thirteen days. On the last day Oba shared out gifts to all the  
people.  
**Ọn'omoshi ne luu Uronyavhegbe, a bhẹ a rọ gi ọba. Ọ r'owa na a.**  
The bride, Urhonyavhegbe, was sent to the Oba. He gave her a room.
- 4  
Est. **Ọ z'ikpotso ali emose na walia khe kẹ tẹlue khu ọ. Ọ bhe a ki ududum'**  
okpotso.  
He gave her ladies in waiting as well as eunuchs to guard her. She grew into a  
big lady  
**Ẹ lẹ na ke lele rọ bhẹ, ẹleyọ l'oghwo lọ m'oba elue.**  
It was only on the day of her arrival she cast eyes on Oba, her husband.
- CCL

- 5  
E.Act. N'ene r̄elue khu e tie khi w̄ew'evha lamaa Ur̄onyavhegbe ọ khi le al'ogwore.  
While waiting on her they refused her going to fetch firewood.  
Ọ ke b̄h̄e vh'ogwa, ọkhi l̄e a f̄ee, gh'onviolimhi ọ banua. Egb' ọmose opfi d̄ene d̄ene.  
She went a firewood fetching. On looking she saw a naked orphan, his penis dangling from side to side.  
Ur̄onyavhegbe ọ li zaki, u wa li mūe t̄ot̄o na l̄ee? Ọ li kh'inena l̄e l̄e  
Urhonyavhegbe said, Your highness, don't you have roasted yam for me? He replied saying  
p̄fin'ene kp̄olel̄e kua. Ọ li san̄o w̄e na l̄e l̄e yagwaa.  
he flung away what he had left. She asked him to pick them up for her.
- 6  
E.Act. Ọ r̄o nāo tu ak̄o v̄h̄o. Ọ li a kpaghīe l̄e kyi or̄e. E b̄h̄e a kyi or̄e no  
He gave her to have a bite. She asked to be helped in fetching some wood.  
They cut a  
v̄hiufo. Ọ l'̄onoom̄o lo v̄h̄o. Ọ lo v̄h̄o. Ọ r'̄et̄sek̄e zusi op'eveveva li o tswaa  
big log with a hollow. He asked the orphan into it. She blocked both ends and carried
- 7  
E.St. b̄h̄e vh'ap̄f̄e. Ọ ke b̄h̄e V'ap̄f̄e, ọ li a tsese l̄e le fīe. Ọ tsore lo owa a b̄h̄e  
it home. On arrival she asked to be helped gently in putting it down. She took it into  
ru ̄on̄om̄o ȳo v̄h̄o le, no gwe ki ughwo. Ur̄onyavhegbe ọ b̄h̄e a f̄el'ọ. Ọ ke  
b̄h̄e a  
her room. She brought him out to act the husband. She first of all circumcised him.
- 8  
E.St. fuu, ̄on'Ur̄onyavhegbe o a t̄es̄e ne ọ m̄e. Ogb̄el̄e ghwo, Egi ọ b̄h̄e vh'ayo lee  
When he was fully grown he had sexual dealing with her. Not long after  
Urhonyavhegbe was pregnant. One day Egi overheard  
d'on̄yo. Ọ sokwu khi ikhumh'ava ̄ee n'eta. Ọ kīe khi l̄e f̄e Ur̄onyavhegbe  
al' ̄on̄om̄o e v̄hes̄eshi.  
two voices in her room and on looking saw someone lying with her.
- 9  
E.St. Utsutsogbe tsun̄e Egi ọ a n̄m̄e. Ọli Ọba, ek̄e nu mhue  
Early next morning Egi reported to the oba. He said, Is your relationship such  
l'oḡb̄o mhodu n'ughw̄ee a gb̄h̄e? Remh'u la līe khi kh'u wa ȳes̄e  
kh'Ur̄onyavhegbe kh̄o she a m̄e?  
as allows people to lie with your wife? Are you claiming ignorance of her pregnancy?  
Ọba ọ li Egi kok'unu. Suli'̄es̄e? Ọ l'Egi ọ m'igha u kha ke  
Oba enquired how she knew. He gave him cuffs to place on them when next  
gwe m̄e kh'e gwe ga v̄hes̄eshi, to w'igha. Ọ liȳo khīe.  
they are seen lying together. Egi did as he was ordered.
- 10  
E.Act. Ur̄onyavhegbe ọ ghie bh'itaa kh'̄onyanya b̄h̄e, kh'ọ gban'itsw'igīe d̄e, ọ  
Urhonyavhegbe sent in haste for his father instructing that he wear the  
hunter's garb, carry  
tsw'ava, a v̄hal'am̄e ku egbe. Ọ b̄h̄e a ru ̄on̄om̄o igha aw̄e le. Ọ r̄o shi ow'egbo.  
his gun, and wet himself. On arrival he removed the cuffs and planted them on himself.

- 11  
E.Act. | **Ọ nu onvio vheseshi, ọ nọmọ ọ na vu.**  
He lay down by the daughter and the orphan left the scene
- 12  
E.St. | **Egi ali Ọba n'ukpokiaa e bhẹ. Ita Uronyavhegbe ọ bhẹ a nme abhi**  
Egi and his friend, the Oba, arrive. Urhonyavhegbe's father explained his  
**lẹ li y'ishemi n'ubi o ke rọ bi lẹ. Ashi ni lẹ mholi iogbo shi ni lẹ ke bhẹ**  
being benighted in the forest. He had to spend the night here where he has a  
daughter.
- 13  
E.St. | **O ghe, gh'abhi lẹ ke li bhẹ a vhekha to lẹ igha. Elo lẹ li?**  
Bu to his dismay see how he was cuffed. What has he done?  
**Ọba ọ li kh'imeli t'unuọ khas'ogbo. Ọr'ikpagho lema li. Egi ọ li**  
Oba begged him not to mention it to anyone. He gave him money  
**ukpa so we lẹ li. Lẹ vhe m'ikhumn'ava? Lẹ ali ọba e je.**  
as compensation. Oba wondered what he should do. Didn't I see two persons?  
They both left the scene.
- (Uwolo)  
(Song intermission)  
Amhinomọ  
okhiyora omiza gbo  
Amhnomọ  
okhiroya omina gbe.
- 14  
E.St. | **Ugbel'oz'esẹ, Egi ọ gwe a kpe. Abk'o ke rọ me we, ọ li ukpa le gwe nwu vhe.**  
On the third day Egi lay waiting and watching. I have caught you again.
- 15  
E.Act. | **gh'okpotso, gh'omose. Ọ gwe to w'igha. Uronyavhegbe oghie bh'inyo ọ bhẹ,**  
This is a lady, this is a man. He leg cuffed them together. Urhonyavhegbe  
**oru okhomi igha awẹ le, ọ rọ shi aw'ọ ali aw'onvio ọ vheseshi.**  
sent for he mother. On her arrival she uncuffed them and cuffed her legs with  
her daughter and they lay together.
- 16  
E.St. | **Ogh'o ke gbe, Egi ali Ọba e gwe khe. E bhẹ a vhe kh'igha el'uronyavhegbe ali**  
inye vh'awe.  
Early the next day, Oba and Egi arrived. They saw her mother and herself in  
cuffs.
- 17  
E.St. | **Inyol'ọ li, a kpọ nme yọ, u wa me lẹ nena? Oki lẹ lẹ ye ni le ke rọ...**  
The mother exclaimed, who has ever seen the like of this? She said she went  
to the market...  
**Ọba ọ li yagwa, pfiesua. Ọ li Egi onogho u ke gwe pfi lẹ shi ena. Ọ li ogole**  
yagwa.  
Oba said what have you led me into again.  
**Ọr'ikpagho ọ rọ lemaa ọ chigbee je. Iyo, avha dobe yesẹ onọ me**  
The Oba pleaded for her silence and gave her
- 18  
E.Act. | **n'oghw'oba. O ke lu elesẹ el'aka rhomi ilimhi kha yesẹ onọ me a n'ughw'oba.**  
some money. Thus it was difficult to know who impregnated Urhonyavhegbe.  
**Ọtsabo ọ a tsabo ga sh'ekẹ kha ka j'Avhioboghie**  
Three days later, it was decided to take some oath to determine who  
impregnated Urhonyavhegbe. The town crier announced that all men will go to  
Avioboghie  
**olimhi gbada el'esẹ amọ na la rhomi ilimhi.**  
Olimi gbada for the oath of innocence.

- 19  
E.Act. **Urhonyavhegbe ọ li ọkhomhi u kha ẹ me kha she rhomi ilimhi, bhe vhojo.**  
Urhonyavhegbe asked the orphan to come when he has observed that oath taking is over.
- U gbol'etseke nabhi ekphasa, ipfiempfiamẹ al'emene a weẹ wa ka ch'okwu.**  
She asked him to smear his body with all sorts of odorous things and smoke and pipe.
- Mhi kha le ke nwie on'okwu chi, mhi de gwo.**  
I shall receive the pipe and take a puff and fall down.
- Ishoyo u kha ke bhe la kpaghie fmhe mhe khu nwu mhe vue, u talase mhe.**  
Then when you come to help me to my feet cross over my legs.
- Ishoyo ilimhi na la romhi o a ke gwe a ghe mhe. O li koh.**  
Then the oath will no longer destroy me.
- 20  
E.St. **Eleyo o ke ramhi, e romhi. Iogbo kuu e romhi. O kha kia khi mhe mhi me n'urhonyavhegbe, Avio boghie gbe mhe.**  
On the appointed day, they all took the oath - if I impregnated Urhonyavhegbe may Avioboghie destroy me.
- Ono ke romhi kuu o vu. A kie kna fee gh'okhomhi. Egwo e khi o a weẹ.**  
Eghwo e e li a dob'o waa.  
Whoever took the oath left. Suddenly came the orphan. Some said he was stinking. Some said they should let him be.
- Ikia ee khuo gbi. Eni e vha gwe dobe r'isue shieke e na vu. Okwu n'oo chi o lo iogbo egwo isue.**  
He had swarms of flies on him. Some ran away because of the stench. Some inhaled the fumes of his pipe.
- 21  
E.Act. **O I'Urhonyavhegbe isue o d'iagbe. Abh'okhomhi o ke re khi le e nw oli vue, o talas'o.**  
Urhonyavhegbe inhaled it and fell swooning to the ground. The orphan tried to help her up and crossed his legs over her.
- O nyanya nme, o o li remhi le chigbe talasie una, o kha kia khi le kpọ liyo ghwe, imheli ikhumhi mwue.**  
He quickly and in low voice said he had just crossed her legs, he should not be punished on the previous crossings.
- Rari khe li zughu zughu oogbo o vha pfa shi o vh'ekẹ no tiọ lina khi nen's khu o vu.**  
Because of the commotion no one took note - he was chased away.

## SUMMARY OF WHOLE TEXT IN ENGLISH

Oba married Urhonyavhegbe who gave birth to Oyakhire. Because the Oba questioned the paternity of the boy and felt the mother had been unfaithful to him, he hated the boy. On the christening day, Oyakhire displayed extraordinary powers on the Oba. From that day onward, the battle lines were drawn between them.

Oba gave different trials to Oyakhire - aimed at getting rid of him. Some of the tasks were impossible. First Oyakhire was to catch the big man-eating hawks; second it was the tiger, and then the python. Oyakhire always succeeded.

Oba under the instigation of Egi told Oyakhire to reproduce the morsels of food he had always left for him right from childhood. Oyakhire did. Then he was asked to plant yam seedlings, make them grow, mature and be harvested the same day. Oyakhire set a counter task to the Oba and so neutralised him, as the Oba could not meet the demand.

Oba asked him to shear his hair and on completion plant it back but Oyakhire countered this by asking Oba to pluck the seeds on a corn cob. On being asked to stick the hair back, he asked the Oba to stick the corn back on the cob.

Oyakhire underwent many trials and overcame all of them. The last was the catching of thunderbolts from the heavens. He succeeded but one of the splintered ones struck his toe and he died. In revenge many of the Oba's subjects died. The almighty intervened at last and after a brief judgment, the normal world order was maintained once again.

#### REFERENCES

- Barthes, R. 1977. *Image-Music-Text*. Glasgow: William Collins & Sons.  
Barthes, R. et al. 1966. *Communications No.8*. Paris: Edition SEUIL.  
Greimas, A.-J. 1984. *Structural semantics: an attempt at a method*. Translated by D.McDowell et al. Lincoln: University of Nebraska Press.  
Masagbor, R. 1983/84. *Oyakhire: a semiotic analysis*. JOLAN 2.  
Prince, Gerald. 1973. *A grammar of stories*. The Hague: Mouton.  
Propp, Vladimir. 1958. *Morphology of the folktale*. Bloomington.  
Todorov, T. 1981. *Introduction to poetics*. Sussex: The Harvester Press.

Revised version received April, 1989.